

# Amphora

Diseño / Design:

Alex Fernández Camps | Gonzalo Milà / 2013

Tipología: Pie

Typology: Floor lamp

Ambiente: Exterior

Environment: Outdoor

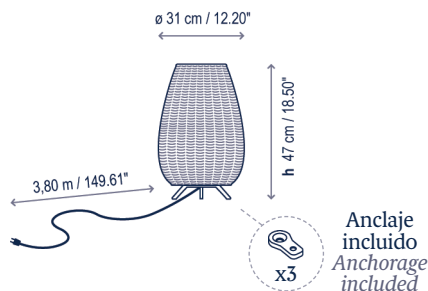

## Descripción técnica / Technical description:

Peso Neto: 2,23 kg  
Net Weight: 2,23 kg

1 Caja/Box | 32 x 32 x 66 cm | 0,07 m<sup>3</sup>  
Peso bruto / Gross Weight: 3,16 kg

Materiales: Aluminio, Polietileno, Fibra Sintética.

Materials: Aluminum, Polyethylene, Synthetic fiber.

Estructuras de metal acabadas con cataforesis y pintura de poliéster epoxi.

Metal surfaces coated with cataphoresis and epoxy polyester paint.

Pantallas tejidas a mano con fibra de polietileno sintética reciclable y no tóxica. Fuente de luz protegida por globo de polietileno y protección UV.

Hand woven with a recyclable and non-toxic synthetic polyethylene fiber. Light source protected by UV resistant polyethylene globe.

Cable sin interruptor, de neopreno negro resistente al agua.

Black waterproof neoprene cable without switch.

Led para conexión directa a red eléctrica  
Led for direct connection to mains voltage

Personalizable: consultar  
Customizable: consult

Certificaciones  
Certifications



Accesorios / Accessories:

R3300114 Anclaje marrón (3 unidades)  
Brown anchorage (3 units)

## Descripción lámpara / Lamps description:

230V 50Hz | IP-66 | 8 W LED / CRI: 90 / 2700K 635 lm fuente de luz / light source |

Ref	Acabados / Finishing	Ean13
33000301126	Marrón - Pantalla Beige Claro Brown - Light Beige Shade	8435493713762
33000301127	Marrón - Pantalla Marrón Rattan Brown - Rattan Brown Shade	8435493713779

Por favor, tenga en cuenta que los tonos de color de la pantalla pueden no ser los mismos en todos los casos. / Please note that the shades may have small variations in tone.

Nota de uso: Para ambientes con alto grado de salinidad, será necesario realizar un correcto mantenimiento de la luminaria. Recomendamos limpiar con un cepillo suave y retirar la sal, el polvo, o la suciedad depositada por la humedad o el viento.

Note of use: For environments with a high salinity, proper maintenance of the luminaire will be necessary. We recommend cleaning it with a soft brush and remove salt, dust, or dirt deposited by moisture or wind.

**bover**  
barcelona lights

Avda. Catalunya 173  
Poligon Ind. Sud  
08440 Cardedeu  
Barcelona, Spain

T. +34 938 713 152  
F. +34 938 462 089  
info@bover.es  
www.bover.es

Familia / Family: Amphora

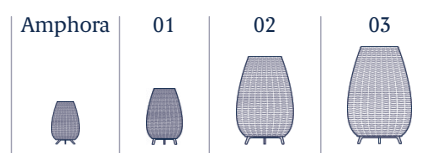

# Amphora 01

Diseño / Design:

Alex Fernández Camps | Gonzalo Milà / 2013

Tipología: Pie

Typology: Floor lamp

Ambiente: Exterior

Environment: Outdoor

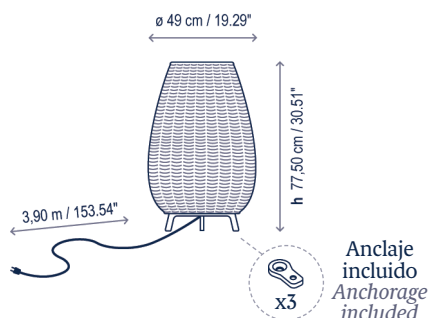

## Descripción técnica / Technical description:

 Peso Neto: 5,87 kg  
Net Weight: 5,87 kg

 1 Caja/Box | 55 x 54 x 86 cm | 0,2554 m<sup>3</sup>  
Peso bruto / Gross Weight: 9,65 kg

Materiales: Aluminio, Acero Inoxidable, Polietileno, Fibra Sintética.

Materials: Aluminum, Stainless steel, Polyethylene, Synthetic fiber.

Opciones Dali/1-10V: consultar

Dali/1-10V options: consult

Estructuras de metal acabadas con cataforesis y pintura de poliéster epoxi.

Metal surfaces coated with cathaphoresis and epoxy polyester paint.

Pantallas tejidas a mano con fibra de polietileno sintética reciclable y no tóxica. Fuente de luz protegida por globo de polietileno y protección UV.

Hand woven with a recyclable and non-toxic synthetic polyethylene fiber. Light source protected by UV resistant polyethylene globe.

Cable sin interruptor, de neopreno negro resistente al agua.

Black waterproof neoprene cable without switch

Personalizable: consultar

Customizable: consult

Bombillas no incluidas

Bulbs not included

Certificaciones  
Certifications



Accesorios / Accessories:

R33014 Anclaje marrón (3 unidades)  
Brown anchorage (3 units)

## Descripción lámpara / Lamps description:

   230V  
50Hz | IP-66 |   2 x MAX 15W LED E-27 A60

Ref	Acabados / Finishing	Ean13
0133003/P741	Marrón - Pantalla Beige Claro Brown - Light Beige Shade	8435493700397
0133003/P742	Marrón - Pantalla Marrón Rattan Brown - Rattan Brown Shade	8435493700403

Por favor, tenga en cuenta que los tonos de color de la pantalla pueden no ser los mismos en todos los casos. / Please note that the shades may have small variations in tone.

Nota de uso: Para ambientes con alto grado de salinidad, será necesario realizar un correcto mantenimiento de la luminaria. Recomendamos limpiar con un cepillo suave y retirar la sal, el polvo, o la suciedad depositada por la humedad o el viento.

Note of use: For environments with a high salinity, proper maintenance of the luminaire will be necessary. We recommend cleaning it with a soft brush and remove salt, dust, or dirt deposited by moisture or wind.

bover

barcelona lights

Avda. Catalunya 173  
Poligon Ind. Sud  
08440 Cardedeu  
Barcelona, Spain

T. +34 938 713 152  
F. +34 938 462 089  
info@bover.es  
www.bover.es

# Amphora 01

LED / LED

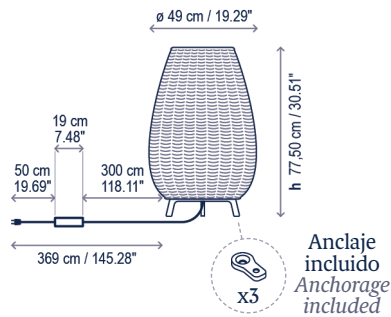

LED regulable / Dimmable LED

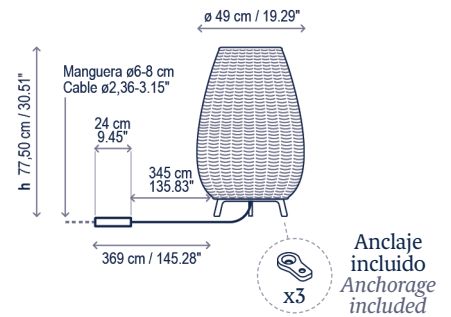

## Descripción técnica / Technical description:

**Peso Neto: 5,87 kg**  
Net Weight: 5,87 kg

**1 Caja/Box | 55 x 54 x 86 cm | 0,2554 m³**  
Peso bruto / Gross Weight: 9,65 kg

**Materiales: Aluminio, Acero Inoxidable, Polietileno, Fibra Sintética.**  
Materials: Aluminum, Stainless steel, Polyethylene, Synthetic fiber.

**Opciones Dali/1-10V: consultar**  
Dali/1-10V options: consult

**Estructuras de metal acabadas con cataforesis y pintura de poliéster epoxi.**  
Metal surfaces coated with cathaphoresis and epoxy polyester paint.

**Pantallas tejidas a mano con fibra de polietileno sintética reciclable y no tóxica. Fuente de luz protegida por globo de polietileno y protección UV.**  
Hand woven with a recyclable and non-toxic synthetic polyethylene fiber. Light source protected by UV resistant polyethylene globe.

**Cable sin interruptor, de neopreno negro resistente al agua.**  
Black waterproof neoprene cable without switch

**Personalizable: consultar**  
Customizable: consult

**Certificaciones**  
Certifications

**Accesorios / Accessories:**

**R33014 Anclaje marrón (3 unidades)**  
Brown anchorage (3 units)

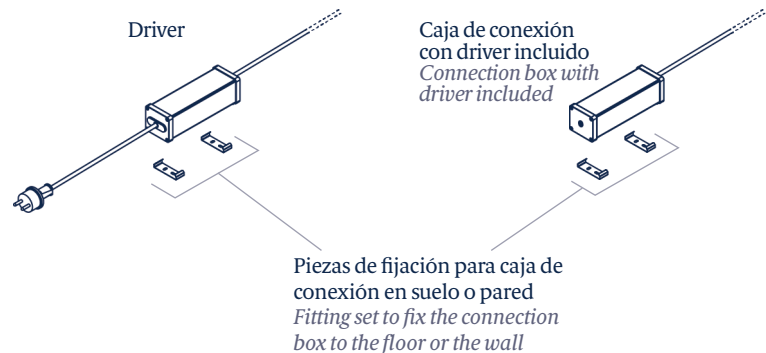

## Descripción lámpara (LED) / Lamps description (LED):



Ref	Acabados / Finishing	Ean13
33001301126	Marrón - Pantalla Beige Claro Brown - Light Beige Shade	8435493733432
33001301127	Marrón - Pantalla Marrón Rattan Brown - Rattan Brown Shade	8435493733456

## Descripción lámpara (LED regulable) / Lamps description (Dimmable LED):



Ref	Acabados / Finishing	Ean13
33001304126	Regulable Triac - Marrón Pantalla Beige Claro Dimmable Triac - Brown Light Beige Shade	8435493738512
33001304127	Regulable Triac - Marrón Pantalla Marrón Rattan Dimmable Triac - Brown Rattan Brown Shade	8435493738413

**bover**  
barcelona lights

Avda. Catalunya 173  
Poligon Ind. Sud  
08440 Cardedeu  
Barcelona, Spain

T. +34 938 713 152  
F. +34 938 462 089  
info@bover.es  
www.bover.es

Familia / Family: Amphora

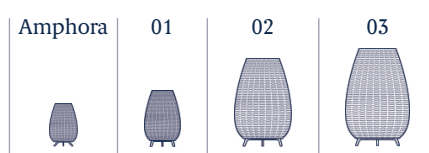

# Amphora 02

Diseño / Design:

Alex Fernández Camps | Gonzalo Milà / 2013

Tipología: Pie

Typology: Floor lamp

Ambiente: Exterior

Environment: Outdoor

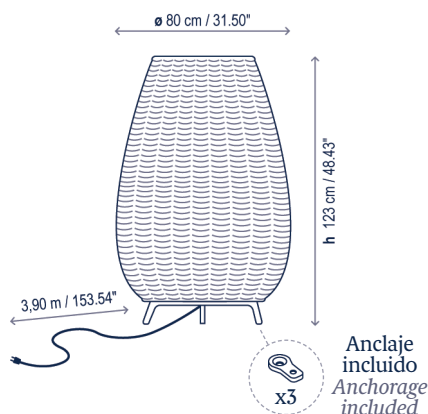

## Descripción técnica / Technical description:

 **Peso Neto: 14,25 kg**  
Net Weight: 14,25 kg

 **1 Caja Madera/Wood Box**  
97 x 97 x 149 cm | 1,4019 m<sup>3</sup>  
Peso bruto / Gross Weight: 55,75 kg

**Materiales: Aluminio, Acero Inoxidable, Polietileno, Fibra Sintética.**

**Materials: Aluminum, Stainless steel, Polyethylene, Synthetic fiber.**

**Opciones Dali/1-10V: consultar**

**Dali/1-10V options: consult**

**Estructuras de metal acabadas con cataforesis y pintura de poliéster epoxi.**

**Metal surfaces coated with cataphoresis and epoxy polyester paint.**

**Pantallas tejidas a mano con fibra de polietileno sintética reciclable y no tóxica. Fuente de luz protegida por globo de polietileno y protección UV.**

**Hand woven with a recyclable and non-toxic synthetic polyethylene fiber. Light source protected by UV resistant polyethylene globe.**

**Cable sin interruptor, de neopreono negro resistente al agua.**

**Black waterproof neoprene cable without switch**

**Personalizable: consultar**

**Customizable: consult**

**Bombillas no incluidas**

**Bulbs not included**

**Certificaciones**  
Certifications



**Accesorios / Accessories:**

**R33014 Anclaje marrón (3 unidades)**  
**Brown anchorage (3 units)**

## Descripción lámpara / Lamps description:

  **230V**  **IP-66**  **2 x MAX 15W LED E-27 A60** 

Ref	Acabados / Finishing	Ean13
0233003/P744	Marrón - Pantalla Beige Claro Brown - Light Beige Shade	8435493700656
0233003/P745	Marrón - Pantalla Marrón Rattan Brown - Rattan Brown Shade	8435493700663

**Por favor, tenga en cuenta que los tonos de color de la pantalla pueden no ser los mismos en todos los casos. / Please note that the shades may have small variations in tone.**

**Nota de uso: Para ambientes con alto grado de salinidad, será necesario realizar un correcto mantenimiento de la luminaria. Recomendamos limpiar con un cepillo suave y retirar la sal, el polvo, o la suciedad depositada por la humedad o el viento.**

**Note of use: For environments with a high salinity, proper maintenance of the luminaire will be necessary. We recommend cleaning it with a soft brush and remove salt, dust, or dirt deposited by moisture or wind.**

**bover**

barcelona lights

Avda. Catalunya 173  
Polígono Ind. Sud  
08440 Cardedeu  
Barcelona, Spain

T. +34 938 713 152  
F. +34 938 462 089  
info@bover.es  
www.bover.es

# Amphora 02

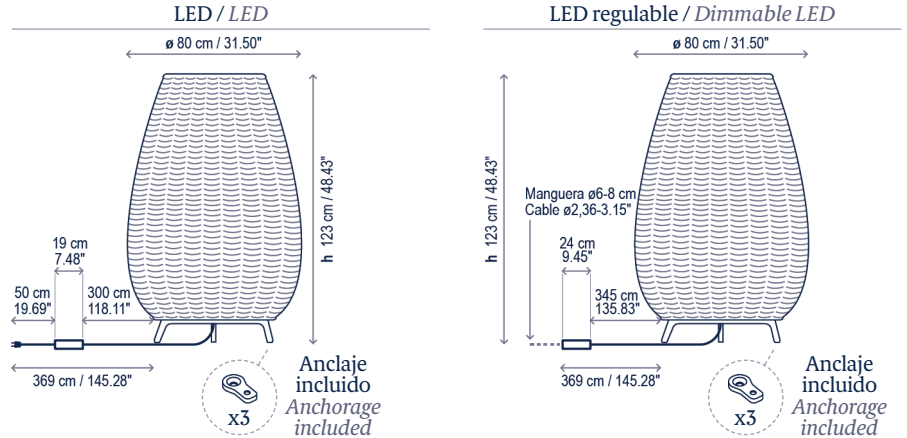

## Descripción técnica / Technical description:

**Peso Neto: 14,25 kg**  
Net Weight: 14,25 kg

**1 Caja Madera/Wood Box**  
97 x 97 x 149 cm | 1,4019 m<sup>3</sup>  
**Peso bruto / Gross Weight: 55,75 kg**

**Materiales: Aluminio, Acero Inoxidable, Polietileno, Fibra Sintética.**  
Materials: Aluminum, Stainless steel, Polyethylene, Synthetic fiber.

**Opciones Dali/1-10V: consultar**  
Dali/1-10V options: consult

**Estructuras de metal acabadas con cataforesis y pintura de poliéster epoxi.**  
Metal surfaces coated with cathaphoresis and epoxy polyester paint.

**Pantallas tejidas a mano con fibra de polietileno sintética reciclable y no tóxica. Fuente de luz protegida por globo de polietileno y protección UV.**  
Hand woven with a recyclable and non-toxic synthetic polyethylene fiber. Light source protected by UV resistant polyethylene globe.

**Cable sin interruptor, de neopreono negro resistente al agua.**  
Black waterproof neoprene cable without switch

**Personalizable: consultar**  
Customizable: consult

**Certificaciones**  
Certifications

**Accesorios / Accessories:**

**R33014 Anclaje marrón (3 unidades)**  
Brown anchorage (3 units)

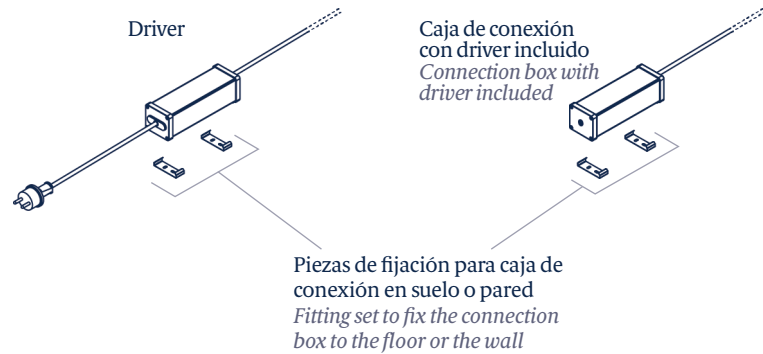

## Descripción lámpara (LED) / Lamps description (LED):



Ref	Acabados / Finishing	Ean13
33002301126	Marrón - Pantalla Beige Claro Brown - Light Beige Shade	8435493733555
33002301127	Marrón - Pantalla Marrón Rattan Brown - Rattan Brown Shade	8435493733579

## Descripción lámpara (LED regulable) / Lamps description (Dimmable LED):



Ref	Acabados / Finishing	Ean13
33002304126	Regulable Triac - Marrón Pantalla Beige Claro Dimmable Triac - Brown Light Beige Shade	8435493738697
33002304127	Regulable Triac - Marrón Pantalla Marrón Rattan Dimmable Triac - Brown Rattan Brown Shade	8435493738710

**bover**  
barcelona lights

Avda. Catalunya 173  
Poligon Ind. Sud  
08440 Cardedeu  
Barcelona, Spain

T. +34 938 713 152  
F. +34 938 462 089  
info@bover.es  
www.bover.es

Familia / Family: Amphora

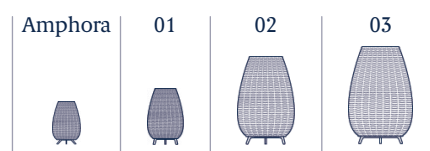



# Amphora 03

Diseño / Design:

Alex Fernández Camps | Gonzalo Milà / 2013

Tipología: Pie

Typology: Floor lamp

Ambiente: Exterior

Environment: Outdoor

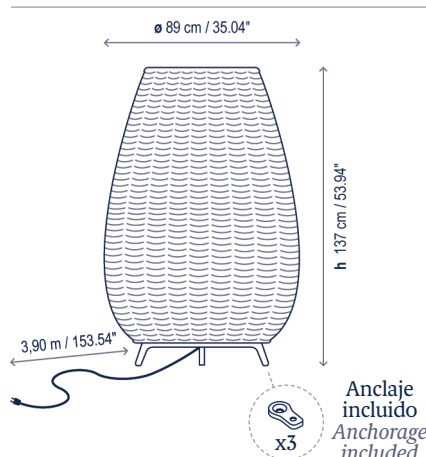

## Descripción técnica / Technical description:

 **Peso Neto: 15,35 kg**  
Net Weight: 15,35 kg

 **1 Caja Madera/Wood Box**  
97 x 97 x 160 cm | 1,5054 m<sup>3</sup>  
Peso bruto / Gross Weight: 56,85 kg

**Materiales: Aluminio, Acero Inoxidable, Polietileno, Fibra Sintética.**

**Materials: Aluminum, Stainless steel, Polyethylene, Synthetic fiber.**

**Opciones Dali/1-10V: consultar**

**Dali/1-10V options: consult**

**Estructuras de metal acabadas con cataforesis y pintura de poliéster epoxi.**

**Metal surfaces coated with cataphoresis and epoxy polyester paint.**

**Pantallas tejidas a mano con fibra de polietileno sintética reciclable y no tóxica. Fuente de luz protegida por globo de polietileno y protección UV.**

**Hand woven with a recyclable and non-toxic synthetic polyethylene fiber. Light source protected by UV resistant polyethylene globe.**

**Cable sin interruptor, de neopreono negro resistente al agua.**

**Black waterproof neoprene cable without switch**

**Personalizable: consultar**

**Customizable: consult**

**Bombillas no incluidas**

**Bulbs not included**

**Certificaciones**

**Certifications**



**Accesorios / Accessories:**

**R33014 Anclaje marrón (3 unidades)**  
**Brown anchorage (3 units)**

## Descripción lámpara / Lamps description:

   **230V**    **2 x MAX 15W LED E-27 A60** 

Ref	Acabados / Finishing	Ean13
0333003/P747	Marrón - Pantalla Beige Claro Brown - Light Beige Shade	8435493700915
0333003/P748	Marrón - Pantalla Marrón Rattan Brown - Rattan Brown Shade	8435493700922

**Por favor, tenga en cuenta que los tonos de color de la pantalla pueden no ser los mismos en todos los casos. / Please note that the shades may have small variations in tone.**

**Nota de uso: Para ambientes con alto grado de salinidad, será necesario realizar un correcto mantenimiento de la luminaria. Recomendamos limpiar con un cepillo suave y retirar la sal, el polvo, o la suciedad depositada por la humedad o el viento.**

**Note of use: For environments with a high salinity, proper maintenance of the luminaire will be necessary. We recommend cleaning it with a soft brush and remove salt, dust, or dirt deposited by moisture or wind.**

**bover**

barcelona lights

Avda. Catalunya 173  
Polígono Ind. Sud  
08440 Cardedeu  
Barcelona, Spain

T. +34 938 713 152  
F. +34 938 462 089  
info@bover.es  
www.bover.es

# Amphora 03

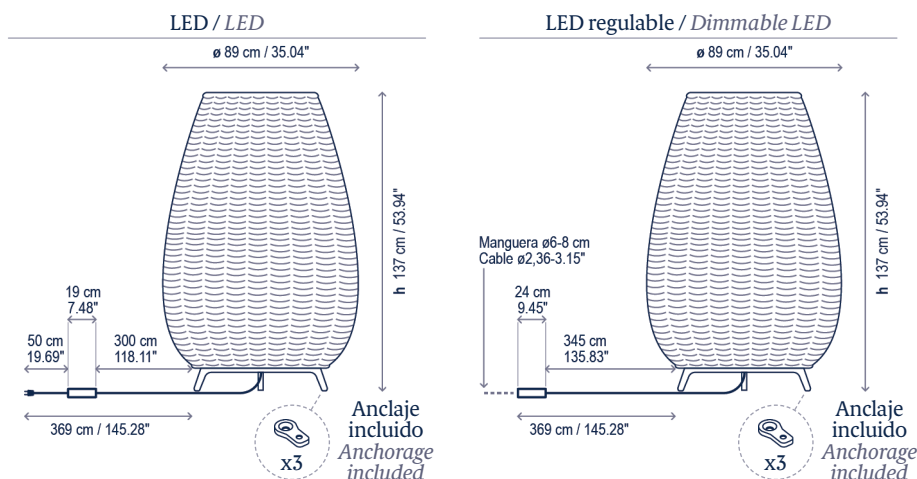

## Descripción técnica / Technical description:

**Peso Neto: 15,35 kg**  
*Net Weight: 15,35 kg*

**1 Caja Madera/Wood Box**  
97 x 97 x 160 cm | 1,5054 m<sup>3</sup>  
**Peso bruto / Gross Weight: 56,85 kg**

**Materiales: Aluminio, Acero Inoxidable, Polietileno, Fibra Sintética.**

*Materials: Aluminum, Stainless steel, Polyethylene, Synthetic fiber.*

**Opciones Dali/1-10V: consultar**  
*Dali/1-10V options: consult*

**Estructuras de metal acabadas con cataforesis y pintura de poliéster epoxi.**

*Metal surfaces coated with cataphoresis and epoxy polyester paint.*

**Pantallas tejidas a mano con fibra de polietileno sintética reciclable y no tóxica. Fuente de luz protegida por globo de polietileno y protección UV.**

*Hand woven with a recyclable and non-toxic synthetic polyethylene fiber. Light source protected by UV resistant polyethylene globe.*

**Cable sin interruptor, de neopreno negro resistente al agua.**

*Black waterproof neoprene cable without switch*

**Personalizable: consultar**  
*Customizable: consult*

**Certificaciones**  
*Certifications*



**Accesorios / Accessories:**

**R33014 Anclaje marrón (3 unidades)**  
*Brown anchorage (3 units)*

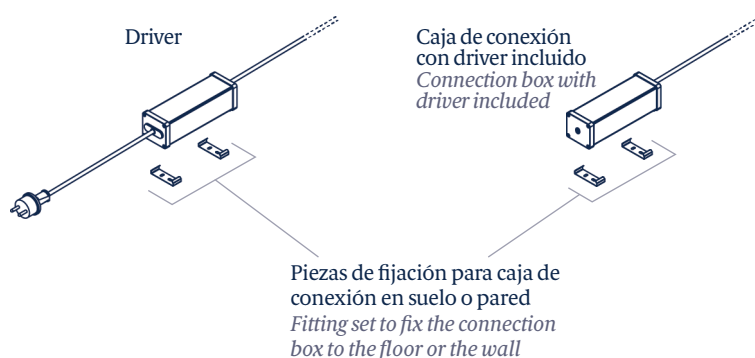

## Descripción lámpara (LED) / Lamps description (LED):



Ref	Acabados / Finishing	Ean13
33003301126	Marrón - Pantalla Beige Claro <i>Brown - Light Beige Shade</i>	8435493733616
33003301127	Marrón - Pantalla Marrón Rattan <i>Brown - Rattan Brown Shade</i>	8435493733647

## Descripción lámpara (LED regulable) / Lamps description (Dimmable LED):



Ref	Acabados / Finishing	Ean13
33003304126	Regulable Triac - Marrón Pantalla Beige Claro <i>Dimmable Triac - Brown Light Beige Shade</i>	8435493738758
33003304127	Regulable Triac - Marrón Pantalla Marrón Rattan <i>Dimmable Triac - Brown Rattan Brown Shade</i>	8435493738734

**bover**  
barcelona lights

Avda. Catalunya 173  
Poligon Ind. Sud  
08440 Cardedeu  
Barcelona, Spain

T. +34 938 713 152  
F. +34 938 462 089  
info@bover.es  
www.bover.es

Familia / Family: Amphora

